

Häny Mixing and Injection Technology

Agitator HRW 800



Agitators ensure continuous operation by holding and homogenizing the mixed suspension and removing any air bubbles by means of a slowly rotating paddle. Optional level sensors enable fully automatic operation.

Agitator

HRW 800

Key features

- ▶ Complete circulation of the tank contents by means of an agitator shaft arranged angled to the tank with mixing paddle (no hard-to-clean static paddles)
- ▶ Slowly rotating paddle for homogenization of the mixed material and removal of existing air bubbles
- ▶ Cleaning opening with safety switch
- ▶ Central hitching point for easy transportation
- ▶ Optional level sensors for consumption-dependent and fully automatic operation

Typical applications

- ▶ Holding tank between mixer and injection pump

3D model



Agitator

Usable content:	800 l
Liquid temperature:	Max. 40°C
Inlet connection:	2½"
Outlet connection:	2½"

Optional

- Level sensors 1", "full - empty"
- Flange connection with butterfly valve 2½"



Electrical data

Voltage:	3x 400/460
Frequency:	50 / 60 Hz
Nominal power:	0.55 / 0.66 kW
Speed:	46.7 / 56.7 min ⁻¹

Weight and dimensions

Approx. weight:	233 kg
Width:	1,144 mm
Height:	1,666 mm
Length:	1,232 mm

Design and dimensions

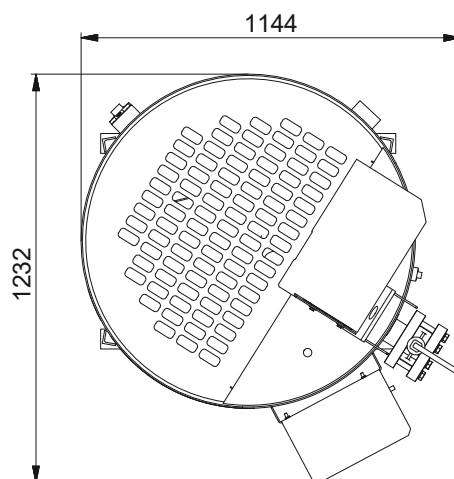
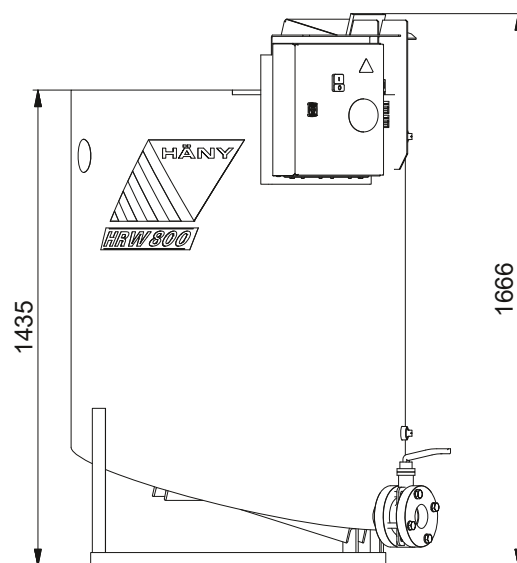

Document No.: PM2-102058-00/10; 18. Legal Notice © Copyright 2018, Häny AG, Jona/Switzerland. Any unauthorized use or copying of the contents or any part hereof is prohibited. Illustrations and photos may show equipment with optional extras. No warranty is made regarding specifications or otherwise. Specifications and equipment are subject to change without notice.



Mixing and Injection Technology

Häny Inc. - Mixing and Injection Technology | 3006 Commerce Square East
Irondale, AL 35210 | Phone/Fax +1 205 201 5505 | www.haeny-inc.com